

LS153 Vacuum Coating Thickness Measuring System Communication Protocol (Customer) V1.12

Contents

I.	Introduction to MODBUS communication protocol.....	2
1.	Hardware parameters	2
2.	Communication function code 03H, 04H (read register value).....	2
3.	Communication function code 05H (triggered single test point re-acquisition).....	3
4.	Communication function code 10H (write register value).....	3
5.	Communication function code 06H (write register value).....	4
6.	Broadcast command	5
II.	Instructions of Vacuum Coating Thickness Measuring System	5
III.	Register address mapping table.....	5
1.	Read integer transmittance value.....	6
2.	Read integer optical density value	7
3.	Read float optical density value	8
IV.	Instrument calibration and zeroing.....	10
1.	Transmittance calibration or zeroing (broadcast command).....	11
2.	Transmittance calibration or zeroing (single-probe calibration).....	11
3.	Optical density calibration or zeroing (broadcast command).....	12
4.	Optical density calibration or zeroing (single-probe calibration).....	13
V.	Communication reply delay setting.....	14
VI.	Triggered probe re-acquisition.....	14
VII.	Error information code table.....	15
VIII.	Instruction of register special value and abnormal handling	15
1.	Abnormal communication description.....	15
2.	Abnormal calibration description	15
3.	Description of special values	16

I. Introduction to MODBUS communication protocol

1. Hardware parameters

- Hardware uses dual RS485, master-slave half-duplex communication, central-switch calling system and switch-central answering communication.
- RS485(1) has setting functions such as data reading, starting measurement, zero adjustment, triggered re-acquisition, station number and baud rate, etc. RS485(2) has only read register function, no write register function (setting function). If data is read only via RS485(2), measurement cannot be started. RS485(1) must also be connected and used to trigger the measurement. Only after the measurement is triggered can RS485(2) read the correct measured value.
- There are 10 bits, 1 start bit, 8 data bits and 1 stop bit, no parity.
- Baud rate: 19200 bps (Special requirements, please specify in the contract).

2. Communication function code 03H, 04H (read register value)

- Note: In this protocol, the 03H and 04H function codes are in common use
- **Host transmit:**

1	2	3	4	5	6	7	8
ADR	03H	Start register high byte	Start register low byte	Register number high byte	Register number low byte	CRC low byte	CRC high byte

- 1st byte ADR : Slave address code (1 ~ 254)
- 2nd byte 03H : Read register value function code
- 3rd and 4th bytes : Register start address to be read
- 5th and 6th bytes : Register number to be read
- 7th and 8th bytes : Checksum of CRC16 from byte 1 to 6

- **When the slave receives correctly, the slave returns:**

1	2	3	4, 5	6, 7	...	M-1, M	M+1	M+2
ADR	03H	The total number of bytes	Register data 1	Register data 2	...	Register data M	CRC low byte	CRC high byte

- 1st byte ADR : Slave address code (= 001 ~ 254)
- 2nd byte 03H : Return to read function code
- 3rd byte : The total number of bytes from 4 to M (including 4 and M)
- 4th and M bytes : Register data
- M + 1, M + 2 bytes : Checksum of CRC16 from byte 1 to M

● **When the slave receives an error, the slave returns:**

1	2	3	4	5
ADR	83H	Information code	CRC low byte	CRC high byte

1st byte ADR : Slave address code (= 001 ~ 254)
 2nd byte 83H : Read register value error
 3rd byte information code : See information code table
 Byte 4 and 5 : Checksum of CRC16 from byte 1 to 3

3. Communication function code 05H (triggered single test point re-acquisition)

● **Host transmit:**

1	2	3	4	5	6	7	8
ADR	05H	Start address (high byte)	Start address (low byte)	Status value (high byte)	Status value (low byte)	CRC code low byte	CRC code high byte

1st byte ADR : Slave address code (1 ~ 254)
 2nd byte 05H : Triggered single test point function code
 3rd and 4th bytes : Address of the test point to be triggered
 5th and 6th bytes : Status value (0x0000 non-triggered, 0xFF00 triggered)
 7th and 8th bytes : Checksum of CRC16 from byte 1 to 6

● **When the slave receives correctly, the slave returns:**

1	2	3	4	5	6	7	8
ADR	05H	Start address (high byte)	Start address (low byte)	Status value (high byte)	Status value (low byte)	CRC code low byte	CRC code high byte

● **When the slave receives an error, the slave returns:**

1	2	3	4	5
ADR	85H	Error message code	CRC code low byte	CRC code high byte

1st byte ADR : Slave address code (1 ~ 254)
 2nd byte 85H : Read register value error
 3rd byte Error message code : Check error information code table
 Byte 4 and 5 : Checksum of CRC16 from byte 1 to 3

4. Communication function code 10H (write register value)

● **Host transmit:**

1	2	3	4	5	6	7
---	---	---	---	---	---	---

ADR	10H	Start register high byte address	Start register low byte address	Register the number of high bytes	Register the number of low bytes	Total number of data bytes
-----	-----	----------------------------------	---------------------------------	-----------------------------------	----------------------------------	----------------------------

8,9	10,11	N,N+1	N+2	N+3
Register data 1 (high byte, low byte)	Register data 2	Register data M	CRC code low byte	CRC code high byte

● **When the slave receive correctly, the slave returns:**

1	2	3	4	5	6	7	8
ADR	10H	Register high byte address	Register low byte address	Register number high bytes	Register number low bytes	CRC code low byte	CRC code high byte

● **When the slave receives an error, the slave returns:**

1	2	3	4	5
ADR	90H	Error message code	CRC low byte	CRC high byte

- 1st byte ADR : Slave address code (= 001 ~ 254)
 2nd byte 90H : Read register value error
 3rd byte Error message code : Check error information code table
 Byte 4 and 5 : Checksum of CRC16 from byte 1 to 3

5. Communication function code 06H (write register value)

● **Host transmit:**

1	2	3	4	5	6	7	8
ADR	06H	Register high byte address	Register low byte address	Register number high bytes	Register number low bytes	CRC code low byte	CRC code high byte

● **When the slave receive correctly, the slave returns:**

1	2	3	4	5	6	7	8
ADR	06H	Register high byte address	Register low byte address	Register number high bytes	Register number low bytes	CRC code low byte	CRC code high byte

● **When the slave receives an error, the slave returns:**

1	2	3	4	5
ADR	90H	Error message	CRC low byte	CRC high byte

	code		
1st byte ADR	:	Slave address code (= 001 ~ 254)	
2nd byte 86H	:	Read register value error	
3rd byte wrong information code	:	Check information code table	
Byte 4 and 5	:	Checksum of CRC16 from byte 1 to 3	

6. Broadcast command

The slave address "0" is a broadcast command.

II. Instructions of Vacuum Coating Thickness Measuring System

1. LS153 Vacuum Coating Thickness Measuring System has the same slave address for the transmitting and receiving probes.. The address of the probe starts from 1 and increases sequentially.
2. In order to make it convenient for customers to communicate with the host computer (PC) or use in the closed-loop control, the station number (probe address) and baud rate of probes can be set. If the user needs to change the communicate parameters, it is recommended that the user use the matching HMI settings. For specific operations, please refer to Section 2.5 "Communication Configuration" in the "HMI User Manual".
3. The instrument receives a read data command, the instrument replies to the data measured in the previous cycle and simultaneously performs the next cycle of data acquisition. The reading interval of a single probe should be more than 300ms.
4. When the instrument receives a zeroing command, make a measurement and then zero adjustment.
5. The instrument provides float and int16 data for the transmittance value and optical density value. The float data provides two decoding methods, "2-3412" and "0-1234". Developers can choose any type according to actual needs. For register addresses, see "**Controller Address Map**".
6. The amount of float indicates the transmittance and optical density. One data requires 4 bytes. So the contents of the two registers are a variable.

III. Register address mapping table

- Out of considerations for compatibility and convenience, mapping of different formats with various addresses are made for the same datum. Please read as needed.
- Each set of probes, independent address and independent communication.

Table 1: Address of integer data decoding process:

Register address	Type	Data content	Instruction

0	Read only	Transmittance	uint16, two decimal places, transmittance expressed as percentage
1	Read only	Temperature	uint16, one decimal place, an integer divided by 10
2	Read only	Optical density	uint16, three decimal places, an integer divided by 1000
3	Read only	Transmittance	3rd and 4th bytes of transmittance, float, "2-3412" decoding
4	Read only	Transmittance	1st and 2nd bytes of transmittance, float, "2-3412" decoding
5	Read only	Temperature	3rd and 4th bytes of temperature, float, "2-3412" decoding
6	Read only	Temperature	1st and 2nd bytes of temperature, float, "2-3412" decoding
7	Read only	Optical density	3rd and 4th bytes of OD, float, "2-3412" decoding
8	Read only	Optical density	1st and 2nd bytes of OD, float, "2-3412" decoding
9	Read only	Transmittance	1st and 2nd bytes of transmittance, float, "0-1234" decoding
10	Read only	Transmittance	3rd and 4th bytes of transmittance, float, "0-1234" decoding
11	Read only	Temperature	1st and 2nd of temperature, float, "0-1234" decoding
12	Read only	Temperature	3rd and 4th of temperature, float, "0-1234" decoding
13	Read only	Optical density	1st and 2nd of OD, float, "0-1234" decoding
14	Read only	Optical density	3rd and 4th of OD, float, "0-1234" decoding

1. Read integer transmittance value

Read the transmittance value of probe No. 1, the corresponding register address is 0, assuming the transmittance value of probe No. 1 is 100.00%.

Send source code -> 01 03 00 00 00 01 84 0A

Receive source code -> 01 03 02 27 10 A2 78

The meaning of the code is as follows:

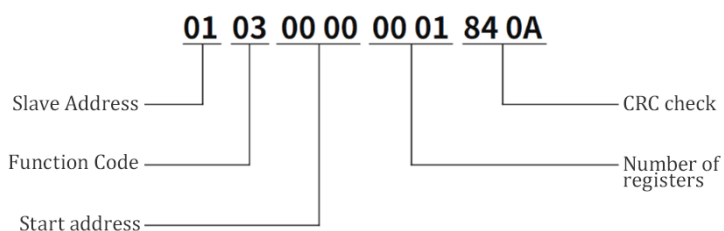

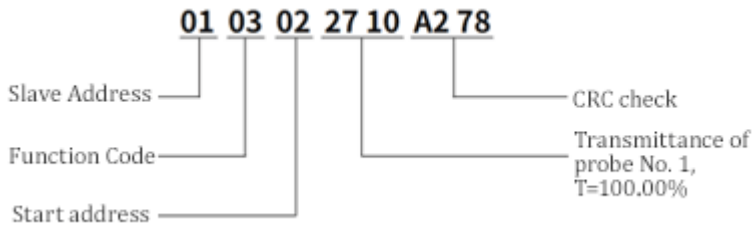

If the reading speed is too fast and the probe data has not been collected yet, it will reply with an error code.

Send source code -> 01 03 00 00 00 01 84 0A

Receive source code -> 01 83 06 C1 32

The meaning of the code is as follows:

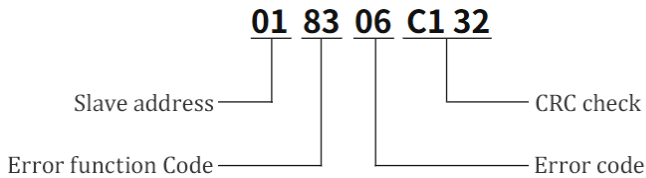

2. Read integer optical density value

Read the optical density value of probe No. 1, the corresponding register address is 2, assuming the optical density value of probe No. 1 is 0.336.

Send source code -> 01 03 00 02 00 01 25 CA

Receive source code -> 01 03 02 01 50 B9 E8

The meaning of the code is as follows:

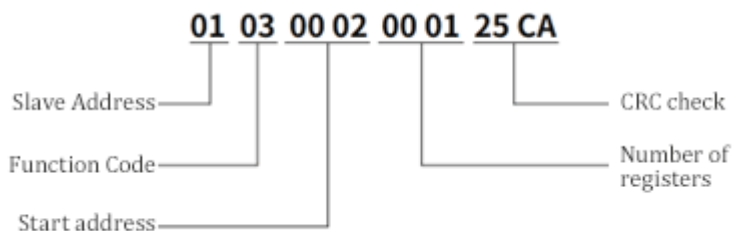

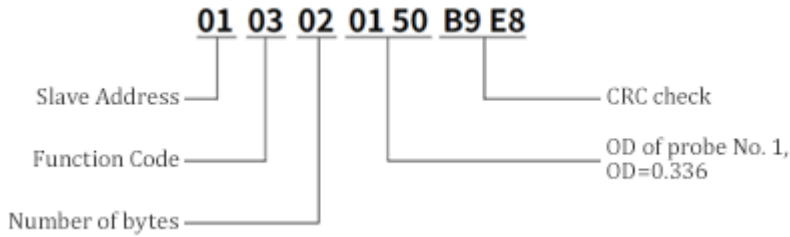

If the reading speed is too fast and the probe data has not been collected yet, it will reply with an error code.

Send source code -> 01 03 00 02 00 01 25 CA

Receive source code -> 01 83 06 C1 32

The meaning of the code is as follows:

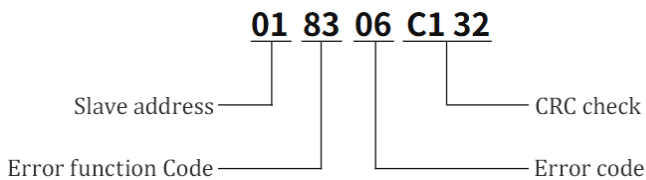

3. Read float optical density value

"2-3412" and "0-1234" decoding instruction

Based on IEEE754 standard, 123.4567 of float amount will be represented by 0x3F9E064B in hexadecimal.

Byte number	1	2	3	4
Byte data	0x3F	0x9E	0x06	0x4B

3412 is the transmission order of "2-3412" decoding data. 1234 is the transmission order of "0-1234" decoding data.

Example: Read the optical density value of probe No. 1. Assume the optical density value is 0.336766.

A. Read the data of decoding "2-3412", which corresponds to the register address 7 and 8, and the code is as follows:

Send source code -> 01 03 00 07 00 02 75 CA

Receive source code -> 01 03 04 6C 9F 3E AC C7 50

The meaning of the code is as follows:

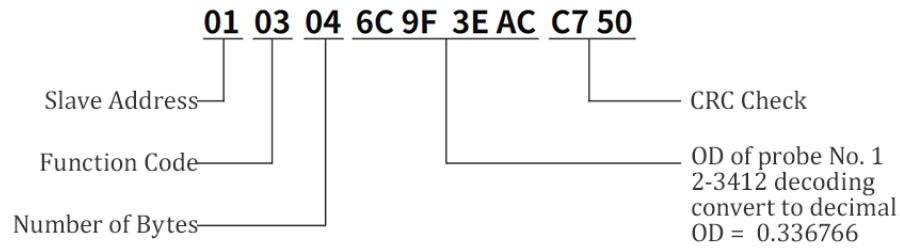
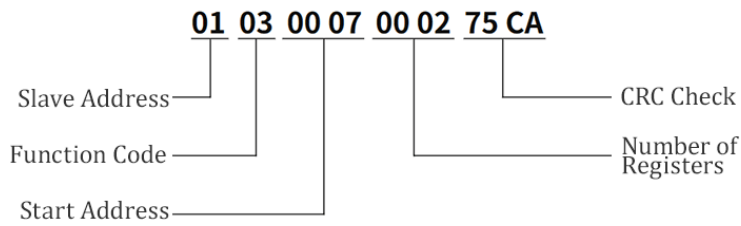

If the reading speed is too fast and the probe data has not been collected yet, it will reply with an error code.

Send source code -> 01 03 00 07 00 02 75 CA

Receive source code -> 01 83 06 C1 32

The meaning of the code is as follows:

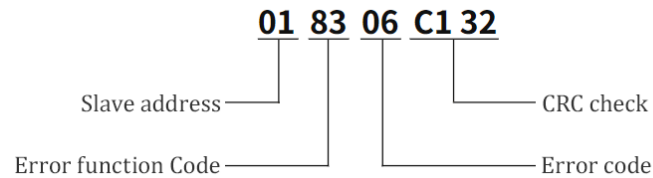

B. Read the data of decoding "1-1234", which corresponds to the register address 13 and 14, and the code is as follows:

Send source code -> 01 03 00 0D 00 02 55 C8

Receive source code -> 01 03 04 3E AC 6C 9F 5A 92

The meaning of the code is as follows:

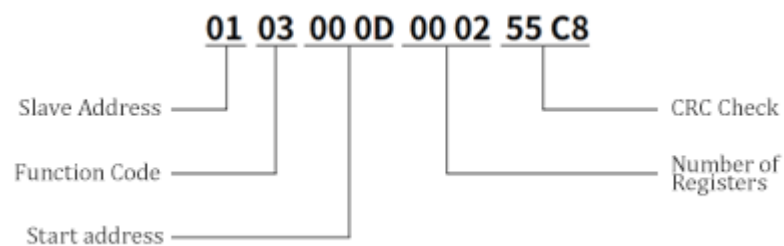

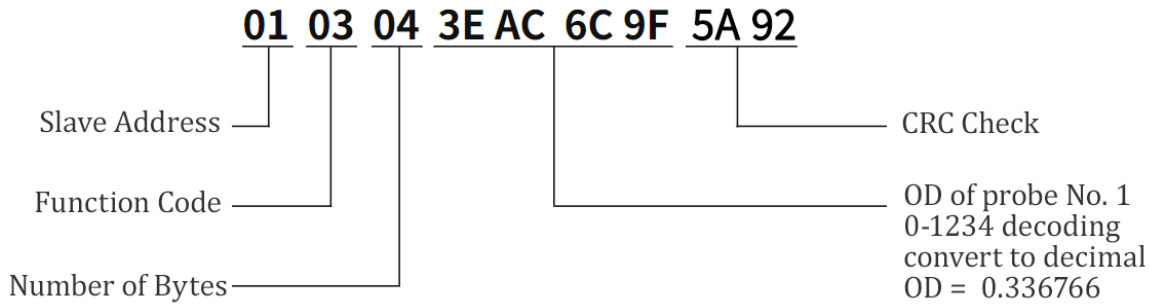

If the reading speed is too fast and the probe data has not been collected yet, it will reply with an error code.

Send source code -> 01 03 00 0D 00 02 55 C8

Receive source code -> 01 83 06 C1 32

The meaning of the code is as follows:

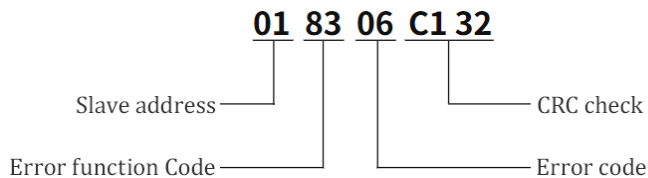

IV. Instrument calibration and zeroing

- The instrument can be calibrated and zeroed by the 06H and 10H function code.
- The calibration operation is to calibrate the instrument by using standard foils or materials with known transmittance.
- Zero adjustment, when there is no test object, the transmittance should be calibrated to 100% or the optical density should be calibrated to 0.
- Supports broadcast commands. One command operates on all the probe in a link. (**Note: wait 50ms after sending the broadcast command before sending the second command**).
- The instrument also supports single-probe operation commands, which can perform calibration and zeroing adjustment on one test point of the controller.

Register address	Type	Data content	Instruction
43	Read and write	Optical density calibration value	int16, three decimals, an integer divided by 1000, signed 16-bit integer data
44	Read and write	The sign of system automatic and manual adjustment	A: "0" means manual adjustment B: "1" means automatic adjustment

45	Read and write	Transmittance calibration value	uint16, two decimals, transmittance expressed as percentage, unsigned 16-bit shaped data
----	----------------	---------------------------------	--

1. Transmittance calibration or zeroing (broadcast command)

- If a sample is placed, the transmittance of the sample can be adjusted to the standard transmittance value.
- When the test slot is empty, zero adjustment can be performed.

For example, make zero adjustment of all probe to 100%.

Send source code -> 00 10 00 2C 00 02 04 00 00 27 10 EF 22

The meaning of the code is as follows:

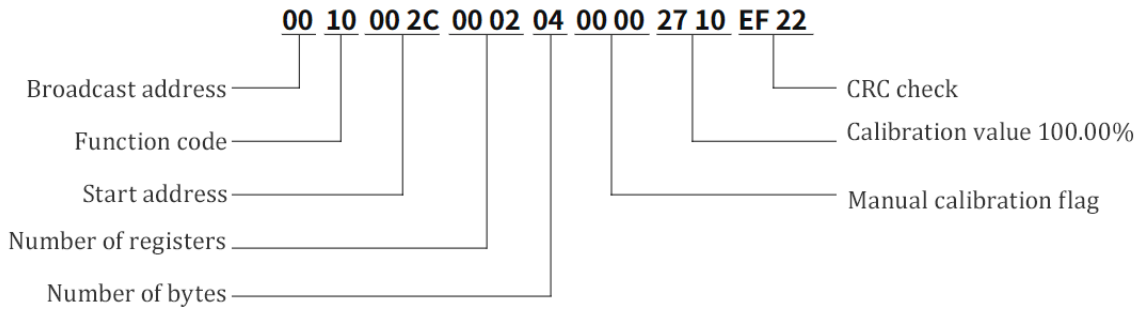

2. Transmittance calibration or zeroing (single-probe calibration)

- If a sample is placed, the transmittance of the sample can be adjusted to the standard transmittance value.
- When the test slot is empty, zero adjustment can be performed.

Take probe No.1 as an example, the transmittance will be calibrated to 100%.

Send source code -> 01 10 00 2C 00 02 04 00 00 27 10 EB DE

Receive source code -> 01 10 00 2C 00 02 80 01

The meaning of the code is as follows:

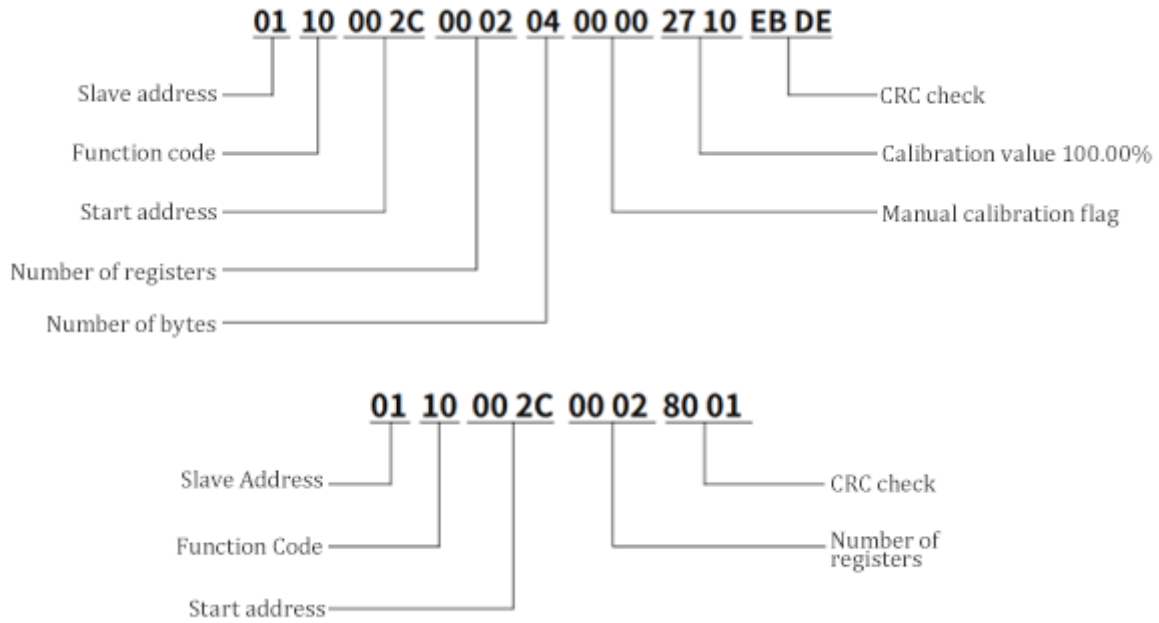

3. Optical density calibration or zeroing (broadcast command)

- If a sample is placed, the transmittance of the sample can be adjusted to the standard optical density value.
- When the test slot is empty, zero adjustment can be performed.

For example, calibrate all the probe of all the controllers to OD 0.

Send source code -> 00 10 00 2B 00 02 04 00 00 00 00 B4 F8

The meaning of the code is as follows:

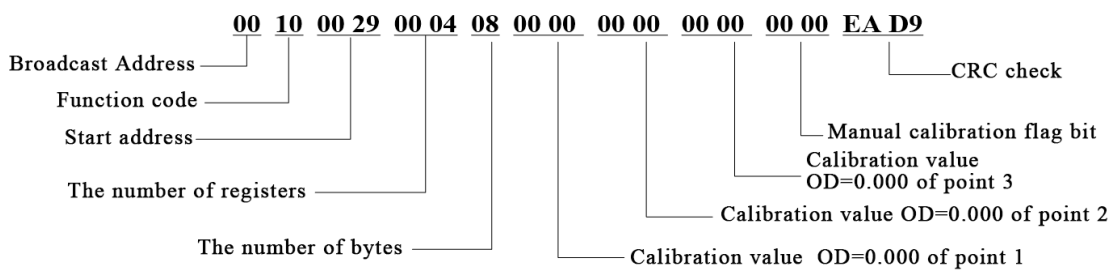

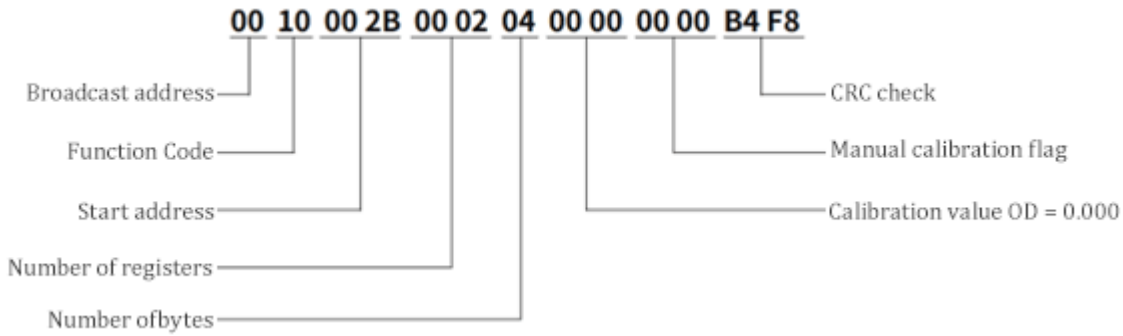

4. Optical density calibration or zeroing (single-probe calibration)

- If a sample is placed, the transmittance of the sample can be adjusted to the standard transmittance value.
- When the test slot is empty, zero adjustment can be performed.

Take probe No.1 as an example, the optical density will be calibrated to OD = 0.

Send source code -> 01 10 00 2B 00 02 04 00 00 00 00 B0 04

Receive source code -> 01 10 00 2B 00 02 31 C0

The meaning of the code is as follows:

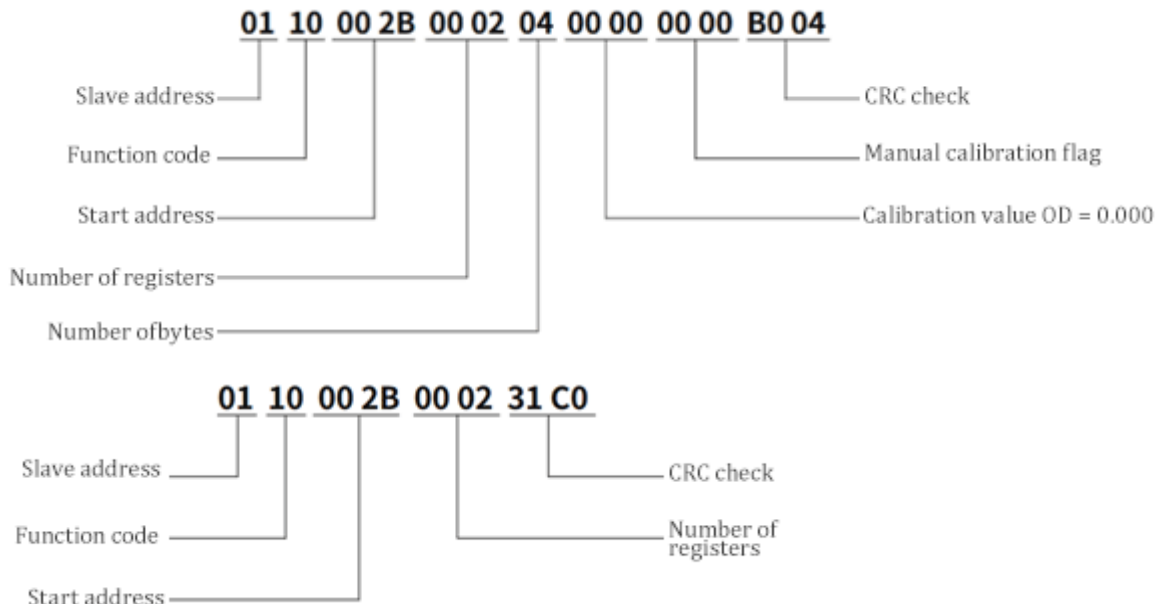

Probe station number and baud rate setting

Register address	Type	Data content	Instruction
48	Read and	RS485① station number	uint16, 16-bit integer data, range (1-247,

	write		except 0xAB).
49	Read and write	RS485① baud rate	uint16, 0 for 4800, 1 for 9600, 2 for 19200, 3 for 38400
50	Read and write	RS485② station number	uint16, 16-bit integer data, range (1-247, except 0xAB)
51	Read and write	RS485② baud rate	uint16, 0 for 4800, 1 for 9600, 2 for 19200, 3 for 38400

Note: After modifying the station number and baud rate of RS485①, you need to communicate with the new station number or baud rate.

System status

Register address	Type	Data content	Instruction
52	Read only	Probe status bit	uint16, 16-bit integer data, bit0: 0 indicates normal calibration, 1 indicates abnormal calibration. Bit1-bit15 is temporarily unused. The default value is 0.

Real-time monitoring of the normal operation of the instrument by reading status bits (registers address).

Note: Possible reasons for abnormal calibration:

1. The light path is blocked by dust. Wipe the lens glass at the corresponding point with a dust-free cloth.
2. In the self-calibration state, there is a sample in the test slot at startup.
3. During manual calibration, there is a large difference between the manual calibration value and the standard value of the calibration plate.
4. The light source is permanently damaged, please send it back to the factory for maintenance.

V. Communication reply delay setting

If the instrument's communication reply is too fast, resulting in code loss, the communication reply delay can be set by the 06H or 10H function code.

Register address	Type	Data content	Instruction
55	Read and write	Communication reply delay option	uint16, Range(0-1000ms)

VI. Triggered probe re-acquisition

When measuring block materials such as glass, a new acquisition is triggered by sending a re-acquisition command to start when the material under test enters the test tank. Triggered a probe reacquisition can be operated with 05H code, or with 06H and 10H codes.

Register address	Type	Data content	Instruction
500	Write	trigger bit	0x0000 indicates no trigger, 0xFF00 indicates a trigger.

VII. Error information code table

Information code	Instruction
01	Invalid information code
02	Wrong memory address or quantity
03	In auto calibration mode, changing the calibration value has no effect.
04	Write register value is not within the allowed range
06	Read data cycle is too short, need to grow the data read cycle (default greater than 300ms)

VIII. Instruction of register special value and abnormal handling

1. Abnormal communication description

After the power is turned on, when the communication indicator in the upper left corner of the display unit shows that there is something abnormal, and the calibration indicator is abnormal, and when there is no temperature display, the user can enter the "System State" interface to check.

If all the probe are abnormal, it indicates that the Human Machine Interface is not communicating. There are three general reasons for the communication abnormality:

1. The power supply of the probe is abnormal. Check whether the 7.5V power cable of the "Probe" and the "Human Machine Interface control box" is correctly connected. The multimeter can be used to measure whether the Power Supply voltage is 7.5V.
2. The communication cable is not wired correctly. Check if the RS485① communication line of the "Probe" and "Human Machine Interface control box" is connected correctly.
3. The probe is damaged and needs to be returned to the factory for repair. If only some of the probe communicate abnormally, it is because the corresponding controller is damaged, or it is because there is a problem with the connection line, and it should be returned to the supplier for repair.

2. Abnormal calibration description

When the calibration indicator in the upper left corner of the HMI is red, or the register value at address 52 is 1, it indicates that the instrument is abnormally calibrated. At this time, the user should enter the "System Status" interface to see which point or points is abnormal, the general calibration status is abnormal for the following four reasons:

1. The light path is blocked by dust. Wipe the lens glass at the corresponding point with a dust-free cloth.
2. In the auto-calibration state, there is a sample in the test slot when the machine is turned on.
3. During manual calibration, the manual calibration value differs greatly from the standard value of the calibration plate.
4. The light source is permanently damaged, please send it back to the factory for repair.

3. Description of special values

When the probe is abnormal, the measured value will be a special value, which is convenient for the user to debug and troubleshoot.

Value	Error message
1111 or 0.1111	Instrument malfunction, return for repair
8888 or 0.8888	Data acquisition error