

# Transmittance Digital Probe

Model: LS501

User Manual V1.02

Please read this manual carefully before use and keep it for future reference.

# 1. Introduction

The Transmittance Digital Probe is an intelligent digital sensor designed for measuring light transmittance or optical density of transparent materials such as glass, window films, solar films, and organic materials. It is suitable for applications requiring real-time monitoring of transmittance or optical density. The probe features dual RS485 communication interfaces and supports the standard MODBUS protocol, allowing direct communication with PLCs, HMIs, industrial computers, and other control systems for real-time data acquisition and monitoring.

The probe operates on an optical measurement principle. A light source illuminates the tested transparent material, while sensors detect both the incident light intensity, and the transmitted light intensity after passing through the sample. The ratio of transmitted light intensity to incident light intensity is calculated as transmittance, expressed as a percentage (%).

**The product complies with the following standards:**

*JJF 1225-2009 Calibration Specification for Transmittance Meter of Automobile*

*JJG 178-2007 Verification Regulation of Visible Near-Infrared Spectrophotometers*

*GB/T 5137.2-2020 Test Methods of Safety Glazing Materials Used on Road Vehicles (Part 2)*

*GB/T 21300-2007 Plastic Pipes and Fittings-Determination of Opacity*

*GB/T 2680-2021 Glass in Building- Determination of Light Transmittance, Solar Direct*

*Transmittance, Total Solar Energy Transmittance, Ultraviolet Transmittance and Related Glazing Factors*

## 2. Parameters

Measurement Wavelength	380nm-760nm or 850nm IR or 530nm green light
Measurement Spot	Ø 8mm
Transmittance Accuracy	± 1% (for uniform colorless materials)
Transmittance Resolution	0.005%
Optical Density Range	0.00 OD - 6.00 OD
Optical Density Resolution	0.01 for 0.00 - 3.00 OD 0.05 for 3.00 - 5.00 OD 0.15 for 5.00 - 6.00 OD
Test Sample Thickness	<100mm

Operating Temperature	-10°C to 60°C
Storage Temperature	-20°C to 70°C
Humidity	<85% (non-condensing)
Data Refresh Rate	300ms (normal mode) /100ms (fast mode)
Communication	Dual RS485
Protocol	MODBUS
Power Supply	7.5V–9V DC
Current	50mA
Power Consumption	375mW
Light Source Probe Size	83.5*38*50(mm)
Receiver Probe Size	79.95*38*50(mm)
Cable Length from Junction Box to Probe	1 m (customizable)
Cable Length from Junction Box to PLCs or HMIs	1 m (customizable)

## 3. Installation Instructions

### 3.1 Probe Installation

Both the front and bottom (optical aperture side) of the probe are equipped with six mounting screw holes, allowing flexible installation according to site requirements.

During installation, ensure that the light-emitting aperture of the light source probe is precisely aligned with the receiving aperture of the receiving probe. The alignment deviation shall not exceed 0.5 mm. The maximum trench width tested was less than 100 mm.

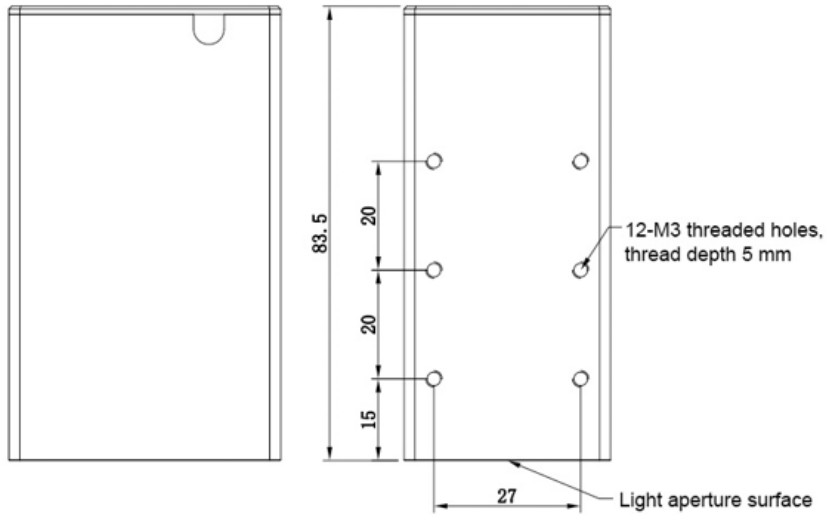
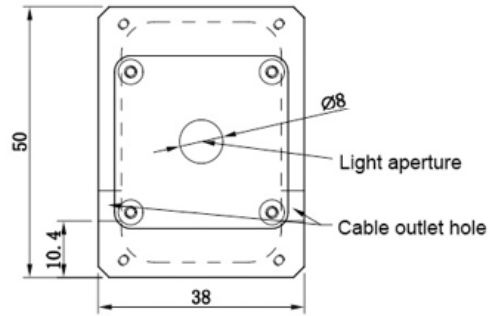

(Light Source Probe Installation Diagram)

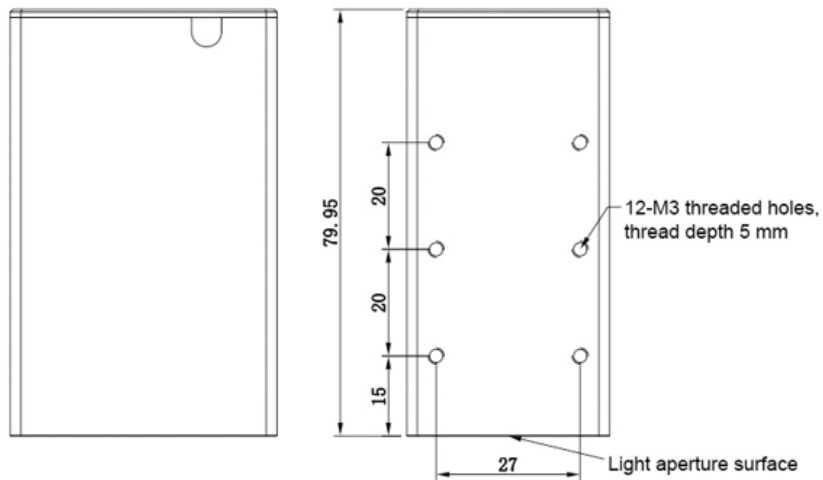
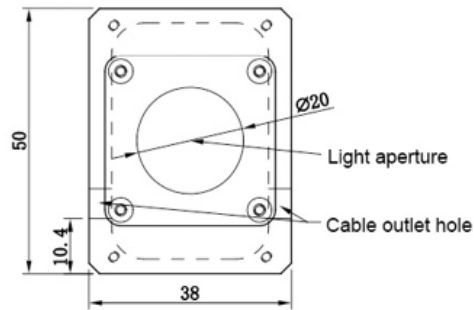

(Receiver Probe Installation Diagram)

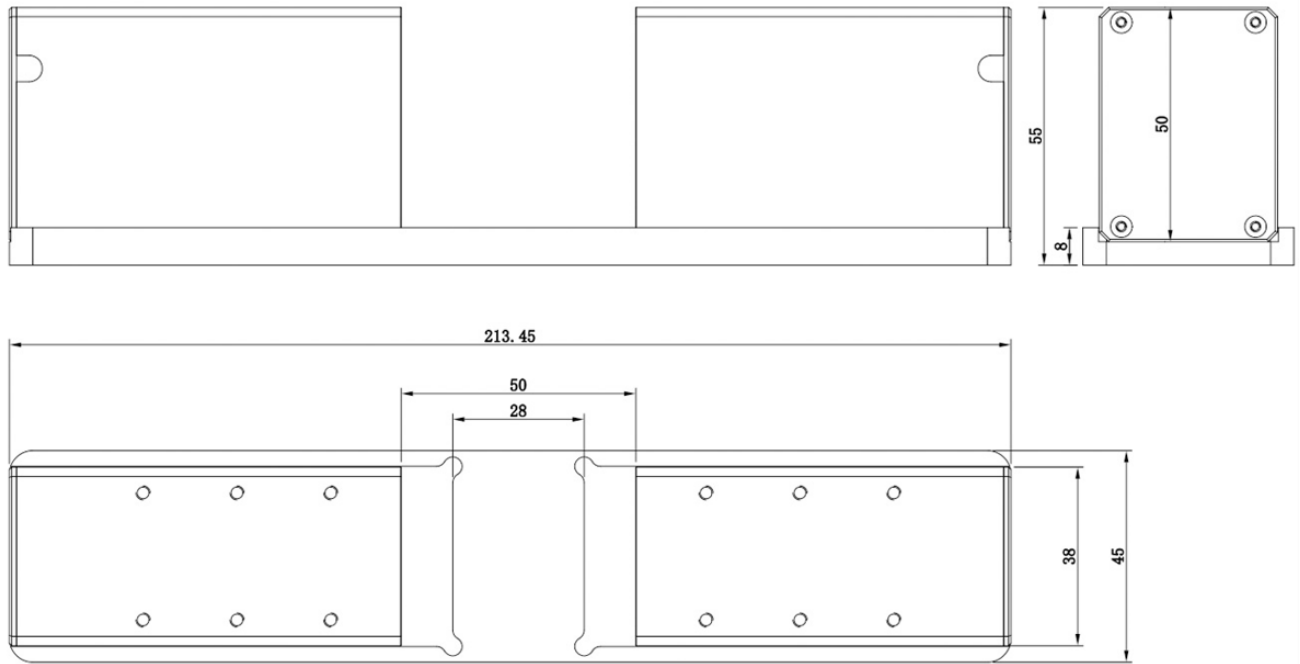

(Probe with Base Plate Dimension Diagram)

### 3.2 Probe Wiring

The probes can be used individually or in multiple groups. When multiple probe sets are used, star topology wiring is recommended.

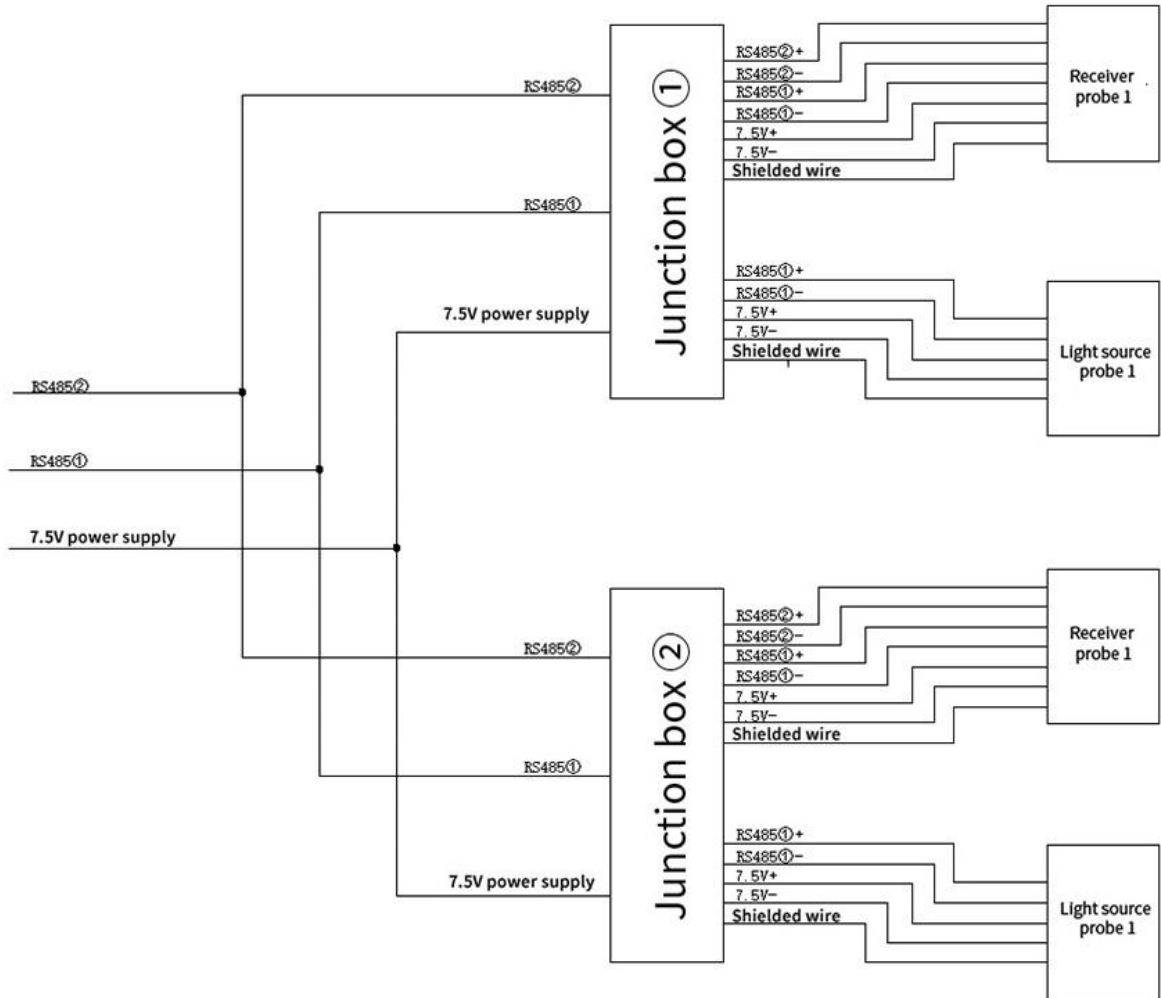

(Star Wiring Diagram)

### 3.3 Junction Box

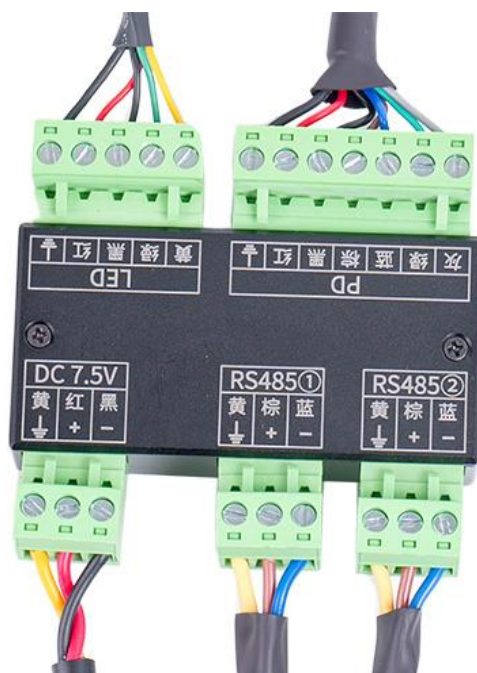

The junction box is equipped with three external connection interfaces: Power supply interface, RS485 ①, RS485 ②. The power cable and RS485 ① communication cable are pre-wired before delivery. The connecting cables used comply with national standards. The specifications of the wires and the wiring method are described below:

**Power cable model:** RVV 3\*0.75mm<sup>2</sup>, three-core unshielded, black outer jacket. The corresponding relationship between the internal core colors and the DC 7.5V terminal ports is as follows:

Power cord type	Inner core color	Terminal block label
RVV 3*0.75 mm <sup>2</sup>	Red	DC7.5V +
	Black	DC7.5V -
	Yellow	DC7.5V 

**Communication cable model:** RVVSP 2\*0.5mm<sup>2</sup>, shielded twisted pair, black outer jacket. The corresponding relationship between the internal core colors and the RS485 terminal ports is as follows:

Communication line type	Inner core color	Terminal block label
RVVSP 2*0.5mm <sup>2</sup>	Brown	RS485 +
	Blue	RS485 -
	Yellow	

Note: When connecting to a computer, an RS485-to-USB or RS485-to-RS232 converter is required.



(Description of Power Cable Cores)



(Description of Communication Cable Cores)

## 4. Communication Parameters

### 4.1 Station Number

The transmittance digital probe supports the standard MODBUS protocol, and the default communication address is “1”.

The communication address of the probe can be modified through the communication protocol. The address setting range is from 1 to 247.

### 4.2 Baud Rate

The default baud rate of the transmittance digital probe is 19200 bps.

The baud rate can be modified through the communication protocol. The available baud rates are 4800, 9600, 19200, and 38400.

### 4.3 Communication Protocol

The probe supports the standard MODBUS protocol. Measurement data can be read, and the communication address and baud rate can be configured through the communication protocol.

For detailed communication commands, please refer to the *Transmittance Digital Probe Communication Protocol*.

## 5. Measurement & Precautions

- (1) During power-on self-calibration, no object may be placed between the light source and receiving probe. Otherwise, calibration will fail and measurement accuracy will be affected. This limitation does not apply when operating in manual mode.
- (2) After normal startup, place the sample into the measurement slot to obtain transmittance or optical density values.
- (3) Optical components are highly sensitive. Keep the probe lenses clean and periodically wipe them with soft cloth and alcohol.
- (4) The device determines the thickness and uniformity of coatings on materials (such as plastic films and glass) indirectly by measuring optical density or transmittance. The results are presented as optical density or transmittance values, not as a direct thickness readout.
- (5) Measurement is realized by optical methods. It adopts a non-contact measurement approach and does not damage the film layer.
- (6) Featuring plug-in aviation connectors, the probe is designed to allow easy installation, removal, and replacement by the user.
- (7) The operating temperature of the instrument is  $-10\text{ }^{\circ}\text{C}$  to  $60\text{ }^{\circ}\text{C}$ . The relative humidity shall be less

than 85% and free from condensation.

- (8) The storage temperature of the instrument is  $-20\text{ }^{\circ}\text{C}$  to  $70\text{ }^{\circ}\text{C}$ . It shall be kept away from heat sources and corrosive substances and stored in a dry environment.
- (9) Strong electromagnetic interference shall be avoided during operation.

## 6. Troubleshooting

- (1) If transmittance continuously displays “11.1100” or OD displays “0.9543”, regardless of whether a test sample is present or after a power cycle, it indicates that the receiving probe or the light source probe corresponding to this test point is faulty. The corresponding probe set (receiving probe and light source probe) shall be returned to the factory for inspection and repair.
- (2) If transmittance continuously displays “88.8800” or OD displays “0.0512”, regardless of whether a test sample is present or after a power cycle, it indicates that no data is being collected at this test point. The corresponding probe set (receiving probe and light source probe) shall be returned to the factory for inspection and repair.
- (3) If the temperature continuously displays “88.8”, or the temperature of a probe continuously displays “88.8” on the “System Status” interface, it indicates that the temperature sensor of the corresponding receiving probe is damaged. The corresponding receiving probe can be returned to the factory for repair.

## 7. Packing List

No.	Product Name	Quantity	Unit
1	Junction box	1	pcs
2	Probe set	1	set
3	User manual	1	pcs
4	Factory calibration certificate	1	pcs
5	7.5V Power supply	1	pcs
6	Probe magnetic suction accessory (Optional)	2	pcs

## 8. After-Sales Service

- (1) The warranty period of the instrument is one year. If a malfunction occurs, the user shall return the



complete instrument set to our company for repair.

- (2) Spare parts are provided to users on a long-term basis, and lifetime maintenance service is offered.
- (3) Instrument calibration service is available.
- (4) Long-term technical support is provided free of charge.

**Manufacturer:** Shenzhen Linshang Technology Co., Ltd.

**Website:** [www.linshangtech.cn](http://www.linshangtech.cn)

**Service Hotline:** 0755-86263411

**Email:** [sales@linshangtech.com](mailto:sales@linshangtech.com)